

**Hydraulic Performance Curves**

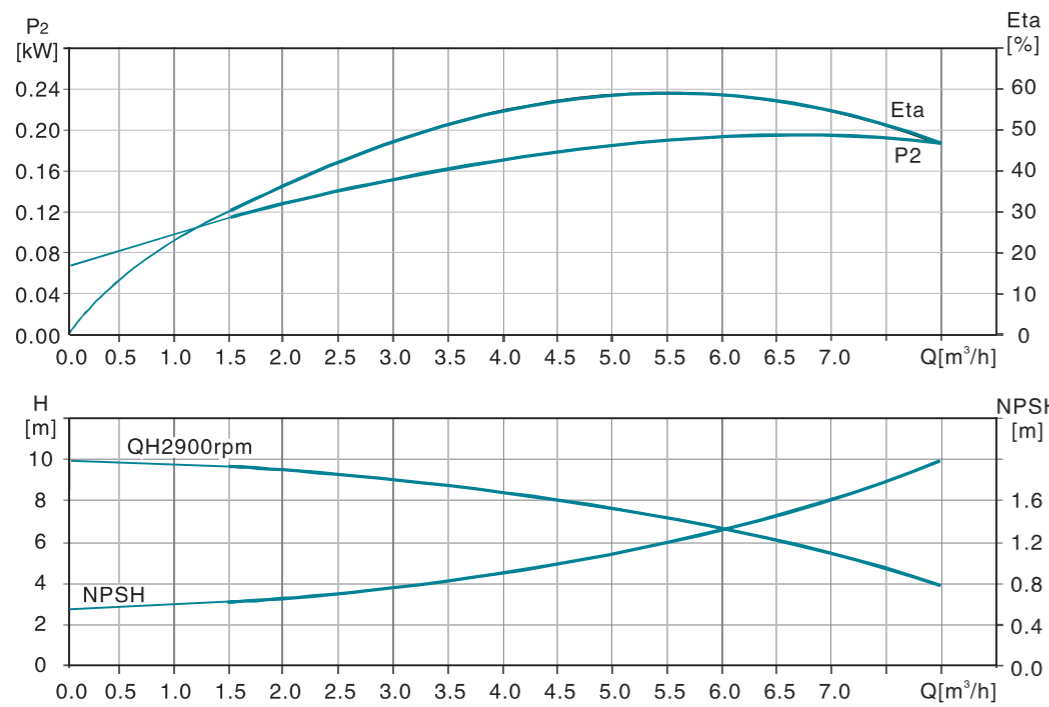

**Dimension Drawing**

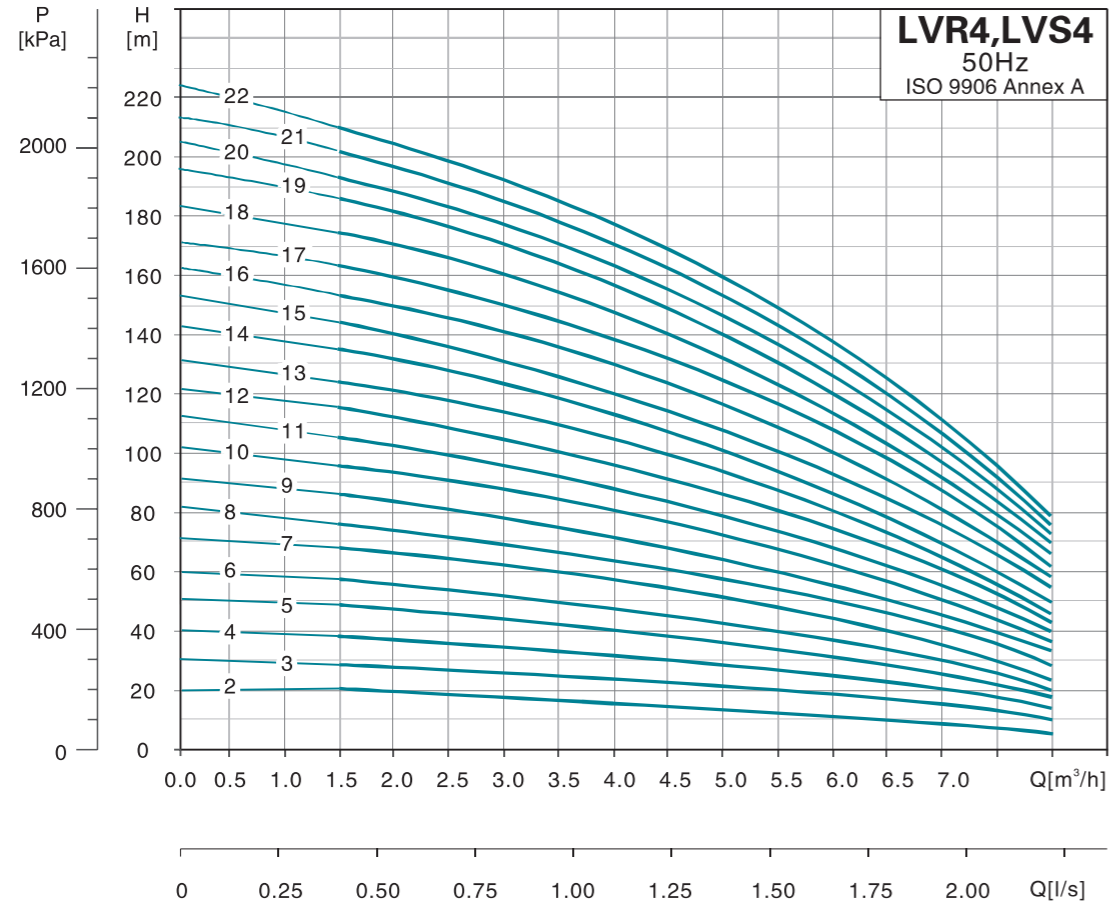
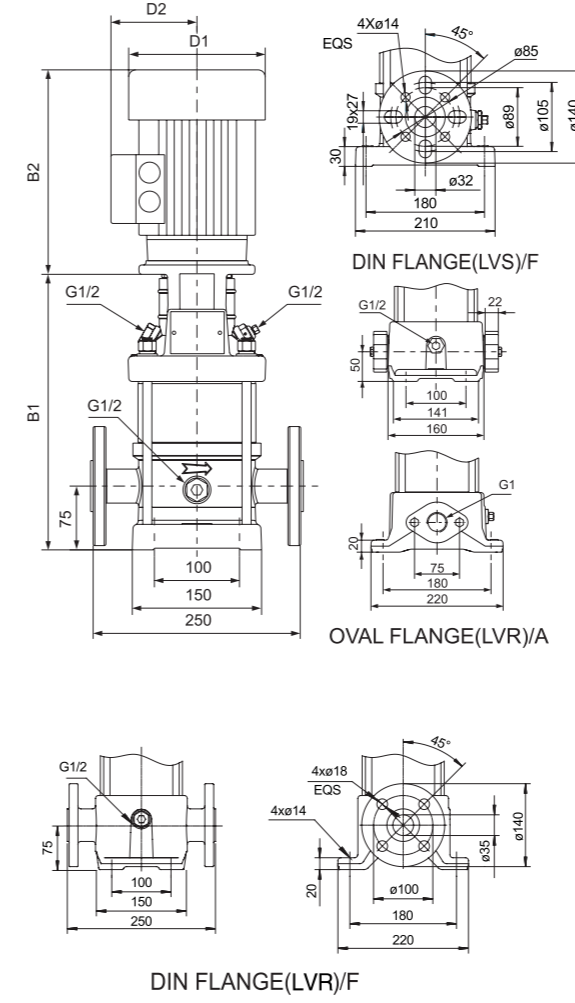

MODEL	OVAL FLANGE(LVR)		DIN FLANGE(LVS)		D1	D2
	B1	B1+B2	B1	B1+B2		
4-2	238	458	263	483	140	110
4-3	265	485	290	510	140	110
4-4	297	547	322	572	160	125
4-5	324	574	349	599	160	125
4-6	351	601	376	626	160	125
4-7	395	685	420	710	180	125
4-8	422	712	447	737	180	125
4-9	449	739	474	764	180	125
4-10	476	766	501	791	180	125
4-11	503	793	528	818	180	125
4-12	530	820	555	845	180	125
4-13	565	895	590	920	190	140
4-14	592	922	617	947	190	140
4-15	619	949	644	974	190	140
4-16	646	976	671	1001	190	140
4-17	673	1003	698	1028	220	150
4-18	700	1030	725	1055	220	150
4-19	727	1057	752	1082	220	150
4-20	754	1084	779	1109	220	150
4-21	781	1111	806	1136	220	150
4-22	808	1138	833	1163	220	150

Note: B1 and B1+B2 of clamp connector and threaded connector are in compliance with that of DIN flange.

MODEL	POWER[kW]	Q[m³/h]	1.5	2.0	3.0	4.0	5.0	6.0	7.0	8.0
4-2	0.37		19	18	17	14.5	13	10.5	8	6
4-3	0.55		28	27	26	23.5	20	18	14	10
4-4	0.75		38	36	34	31.5	27	24.5	18	13
4-5	1.1		47	45	43	40.5	34	31.5	23	17
4-6	1.1		56	54	52	47.5	41	36	28	20
4-7	1.5		66	63	61	57	48	44.5	34	24
4-8	1.5		74	72	70	64	55	49.5	38	27
4-9	2.2		86	81	78	72	63	56	44	32
4-10	2.2		96	90	87	81	71	64	50	34
4-11	2.2		105	99	95	88	78	69	53	39
4-12	2.2	H(m)	114	108	104	96	85	75	57	41
4-13	3.0		123	117	113	103	93	83	63	45
4-14	3.0		136	126	122	114	101	90	69	48
4-15	3.0		142	135	131	120	108	96	73	52
4-16	3.0		152	144	140	129	115	102	78	55
4-17	4.0		163	153	149	137	122	108	83	62
4-18	4.0		175	162	158	145	129	115	89	65
4-19	4.0		183	171	168	155	137	123	95	67
4-20	4.0		192	180	176	161	144	128	99	72
4-21	4.0		203	210	184	169	152	134	103	75
4-22	4.0		211	200	192	177	160	139	108	79