

Application

- It can be used to transfer clean water or other liquids similar to water in physical and chemical properties. It is suitable for industrial use and urban water supply, pressure boosting for high buildings and fire fighting, garden irrigation, long-distance water transfer, heating ventilation and air controlling, circulation and pressure boosting for cold and hot water, and supporting equipment etc.

Pump

- Cast iron pump body and support under special anti-rust treatment
- Stainless steel impeller
- AISI 304 shaft
- Max. liquid temperature: +60°C
- Max. suction: +8 m

Motor

- C&U bearing
- Motor with copper winding
- Built-in thermal protector for single phase motor
- Insulation class: F
- Protection class: IPX4
- Max. ambient temperature: +40°C



Identification Codes

A C m 37

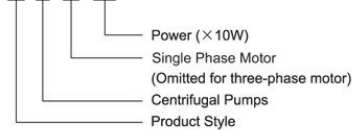

Technical Data

MODEL		POWER		Q (m³/h)																
Single Phase	Three Phase	kW	HP	0	0.6	1.2	1.8	2.4	3.0	3.6	4.2	4.8	5.4	6.0	6.6	7.2	7.8	8.4	9.0	
				Q (l/min)																
				0	10	20	30	40	50	60	70	80	90	100	110	120	130	140	150	160
ACm25	AC25	0.25	0.3	17	16.5	16	15.5	14.5	13.5	12.5	10.5	8								
ACm37	AC37	0.37	0.5	23	21.5	21	20.5	19.5	18	17	15.5	14	12							
ACm60	AC60	0.6	0.8	27	26.5	26	25	24.5	22.5	20	17	14	10							
ACm75	AC75	0.75	1.0	35	34.5	33.5	33	32	31	29	27	24	20	16						
ACm110	AC110	1.1	1.5	40	39	38.5	38	37	36	34.5	33	31.5	29	26	23	20				
ACm150	AC150	1.5	2	48			45.5	44.5	43.5	42.5	41.5	40.5	39	37	34.5	31	27	22		
ACm220	AC220	2.2	3	55			53	52.5	51.5	50.5	49.5	48.5	47	45.5	43.5	40	36.5	32.5	28	

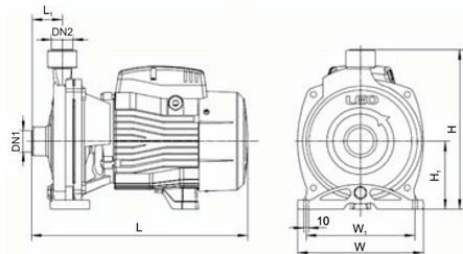

Dimension

Model	DN1	DN2	L (mm)	W (mm)	H (mm)	L ₁ (mm)	W ₁ (mm)	H ₁ (mm)
ACm25	1"	1"	270	157	216	42	122	90
ACm37			270	157	216	42	122	90
ACm60			298	190	240	44	160	90
ACm75			298	190	240	44	160	100
ACm110	1 1/4"	1"	353	206	263	50	178	112
ACm150			360	240	286	51	207	115
ACm220			360	240	286	51	207	115

Hydraulic Performance Curve

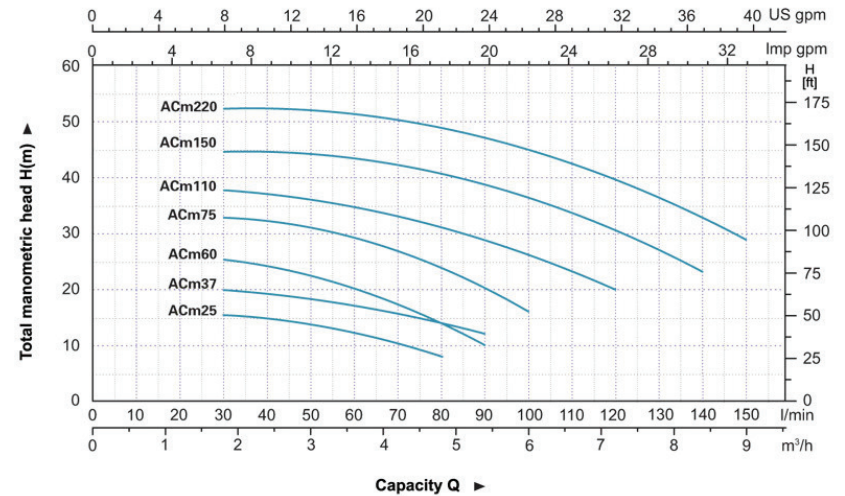

Materials Table

No.	Part	Material
1	Pump body	HT200
2	Impeller	AISI 304
3	O-ring	NBR
4	Mechanical seal	Carbon/ceramic
5	Bracket cover	HT200
6	Support	ZL102
7	Terminal board	PC
8	Stator	
9	Capacitor box	ABS
10	Capacitor	
11	Rotor	
12	Bearing	
13	End cover	ZL102
14	Fan	PP
15	Fan cover	PP

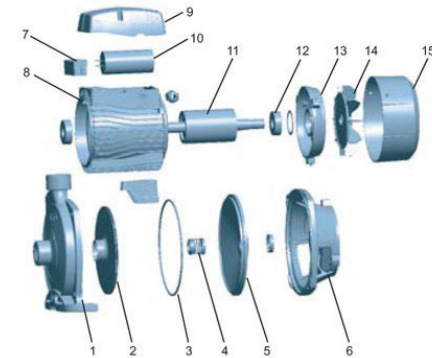

Package Information

Model	GW (Kgs)	L (mm)	W (mm)	H (mm)	Quantity (PCS/20 TEU)
ACm25	7	287	180	230	2322
ACm37	8.4	290	185	239	2124
ACm60	11	325	210	270	1464
ACm75	13.4	333	215	260	1384
ACm110	17.8	383	233	287	987
ACm150	22.8	425	265	310	767
AC220	23.3	425	265	310	751